

M1

User manual | American English for Canada

Welcome to the Permobil family

We hope that you enjoy your new power wheelchair. Permobil's founder, Dr. Per Uddén, believed that every person has the right to have his or her disability compensated as far as possible using the same technology that we all use in our everyday life. Your new wheelchair is a state-of-the-art medical device designed to achieve this goal by providing unparalleled convenience, comfort, and technology.

Produced and published by Permobil

Edition: 19

Date: 2024-06-11

Order no: 336699 eng-CAN

How to contact Permobil

Permobil Inc.
300 Duke Drive
Lebanon, TN 37090
USA



+1 800 736 0925



+1 800 231 3256



support@permobil.com



www.permobil.com



Production units. See page 65.

Head office of the Permobil group

Permobil AB
Klökanvägen 16
863 41 Sundsvall
Sweden



+46 60 59 59 00



info@permobil.com



www.permobil.com

1	Introduction	4			
2	Overview	5			
2.1	Wheelchair specification	6	4.9.4	Manual leg rest	45
2.2	Tool bag	7	4.9.5	Swing away leg rest	45
2.3	General control panel	8	4.9.6	Footplate on a power leg rest	47
2.4	Omni2	9	4.9.7	Footplate on a manual leg rest	48
2.5	Lights and reflectors	10	4.9.8	Footplate on a swing away leg rest	49
2.6	Wheels	11	4.9.9	Fixed panel holder	50
2.7	Tie-down points	12	4.9.10	Parallel panel holder	53
2.8	Serial number label	13	4.9.11	Positioning belt	55
2.9	Accessories	14			
2.10	Spare parts	15	5	Maintenance	56
2.11	User manual	16	5.1	Maintenance and inspection schedules	57
			5.2	Cleaning	58
3	Safety	17	5.3	Inflating the drive wheel tires	60
3.1	Types of warning signs	17	5.4	Positioning belt	60
3.2	Warning signs	17	6	Troubleshooting	61
3.3	Labels	21	7	General information	63
4	Wheelchair usage	23	7.1	Warranty	63
4.1	Driving the wheelchair	23	7.2	Standards and regulations	63
4.2	Seat functions	26	7.3	Reporting incidents	63
4.3	Charging the batteries	28	7.4	Scrapping and recycling	63
4.4	Freewheel mode	28	7.5	Technical specifications	64
4.5	Vehicle transportation	29			
4.6	Air transportation	32			
4.7	Main circuit breaker	34			
4.8	Wheelchair storage	34			
4.9	Manual adjustments	35			
4.9.1	Headrest with link hardware	35			
4.9.2	Backrest	38			
4.9.3	Armrest	43			

1 Introduction

Before you use your wheelchair for the first time, you must read and understand the contents of this user manual. It instructs you on how to properly and safely use and care for your wheelchair. You must also read and understand the user manuals for your specific accessories before you use your wheelchair. This user manual and additional information concerning our products are available at www.permobil.com or by telephone.

Your power wheelchair is a complex medical device prescribed to you by your healthcare provider and configured to meet your needs. Permobil is not responsible for inappropriate prescription or selection of models or features, or for improper use of or modifications to the wheelchair. If the wheelchair has an unexpected impact on your health, contact your healthcare provider.

The illustrations in this user manual are generic and may not be exact depictions of your wheelchair.

2 Overview

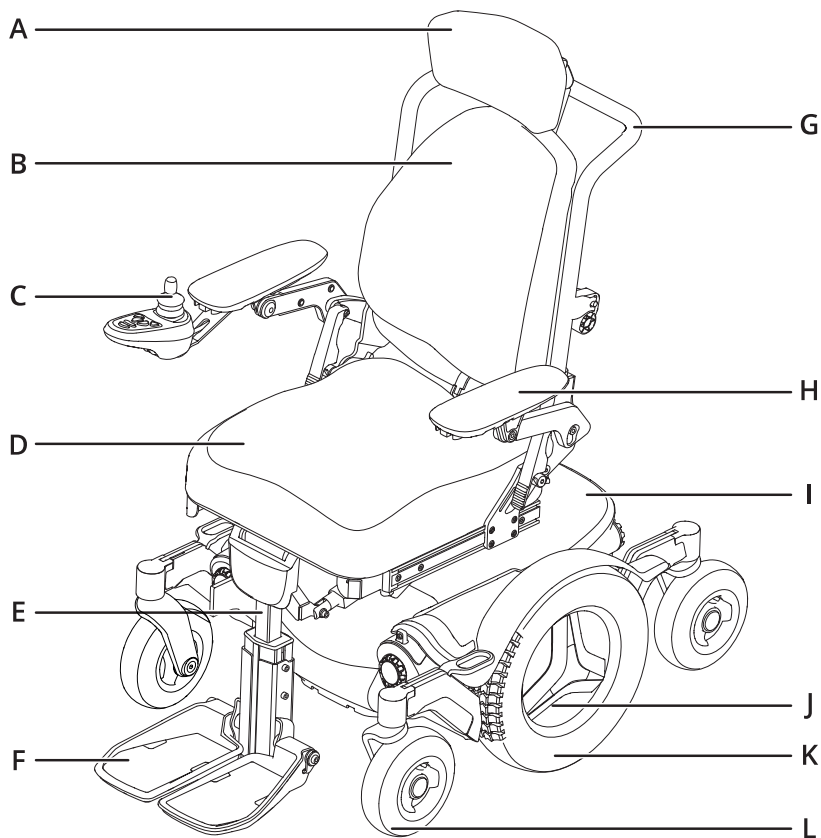

This chapter gives you an overview of your wheelchair. The parts on the overview image are described in more detail throughout the manual.

The M1 is a mid-wheel drive power wheelchair for indoor and outdoor use. It is intended for people limited to a seated position.

The expected service life of this product is five years.

- | | |
|-------------------------|-------------------------------|
| A. Headrest | G. Backrest frame |
| B. Backrest | H. Armrest |
| C. Control panel | I. Chassis |
| D. Seat | J. Serial number label |
| E. Leg rest | K. Drive wheel |
| F. Footplate | L. Caster wheel |

2.1 Wheelchair specification

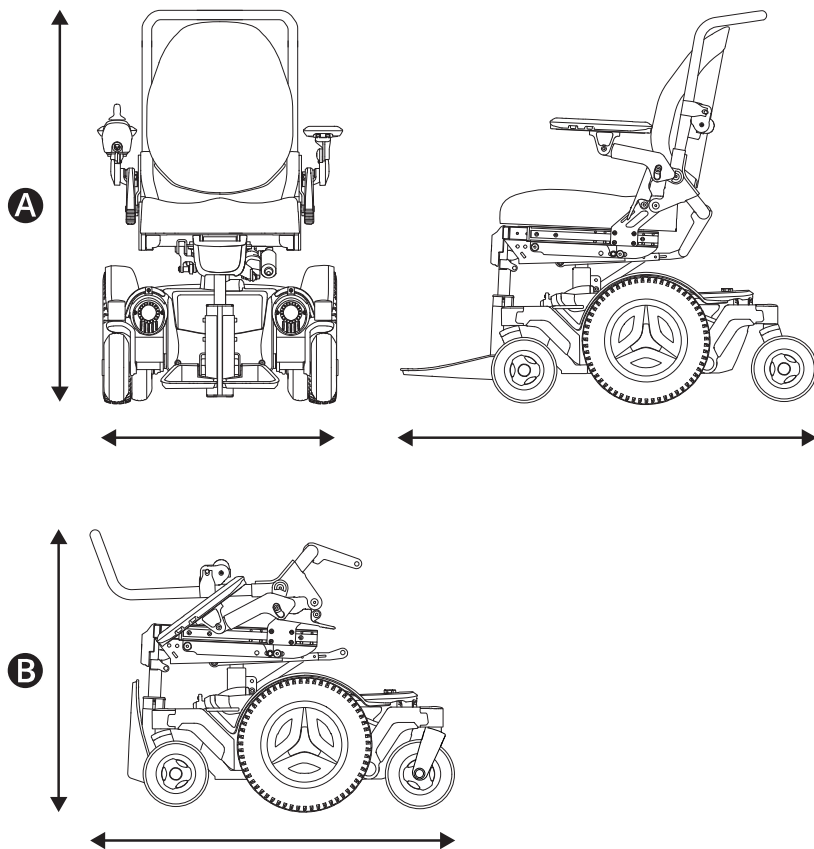

Product name: **M1**

Wheelchair class: **B**

A Height, width, and length
Height: 980–1500 mm (38.5"–59")
Width: 610–800 mm (24"–31.5")
Length: 1090–1280 mm (43"–50.5")

B Smallest transportation size
Height: 620–670 mm (24.5"–26.5")
Width: 610–800 mm (24"–31.5")
Length: 820 mm (32")

👤 Weight specification

Wheelchair with batteries: 143 kg (315 lb.)

Maximum user weight: 136 kg (300 lb.)

The maximum user weight can vary depending on the wheelchair configuration.

2.2 Tool bag

A

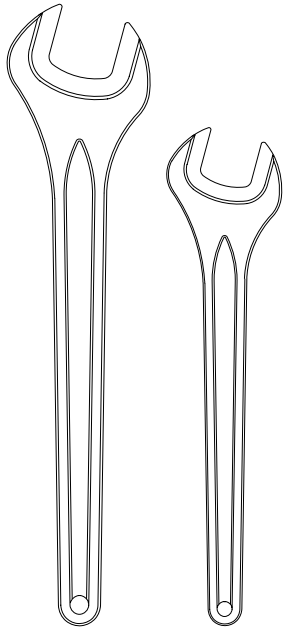

B

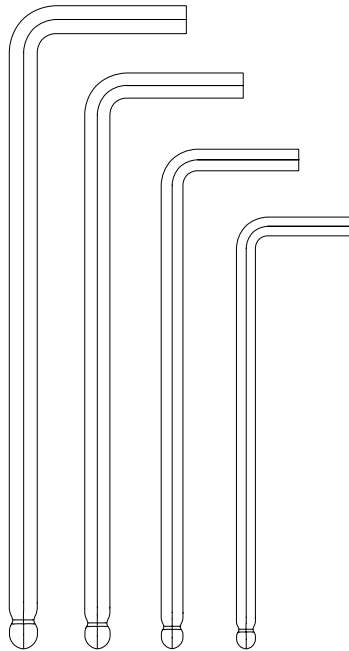

C

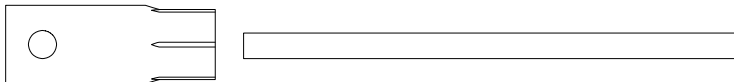

The wheelchair comes with a tool bag for maintenance and adjustments. It contains the following tools:

A Wrench

general maintenance

11 mm

13 mm

B Allen keys

general maintenance and seat adjustment

2–6 mm

C Socket wrench

general maintenance

15 mm

2.3 General control panel

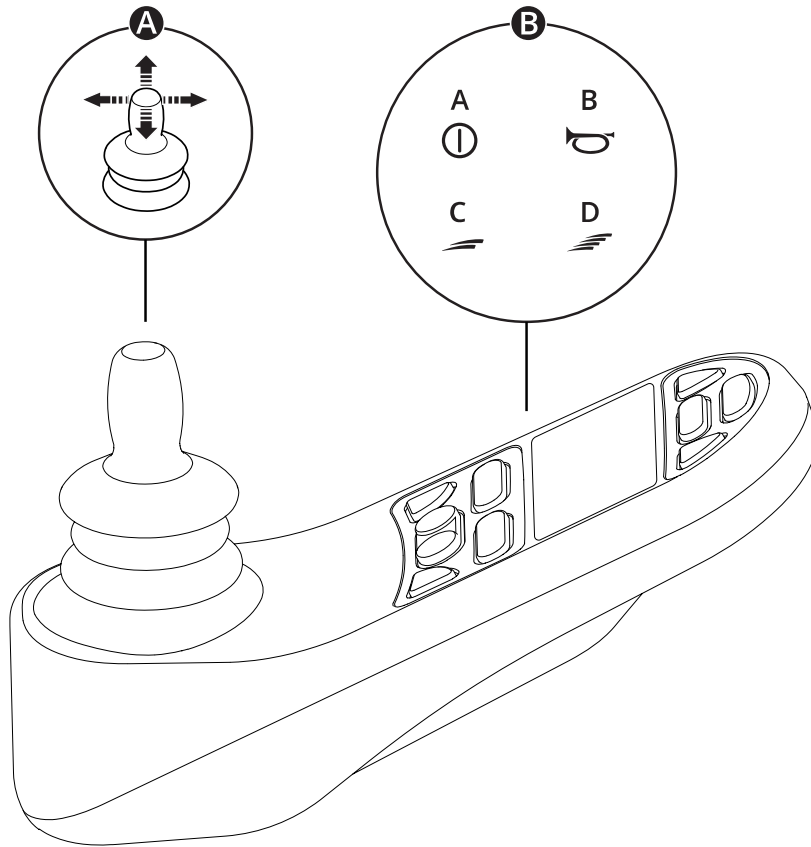

A Joystick

B Example of button functions

A. On/off

B. Horn

C. Decrease maximum speed

D. Increase maximum speed

For more information, see the user manual of your control panel:



https://documentation.permobil.com/manuals/control_panels/

2.4 Omni2

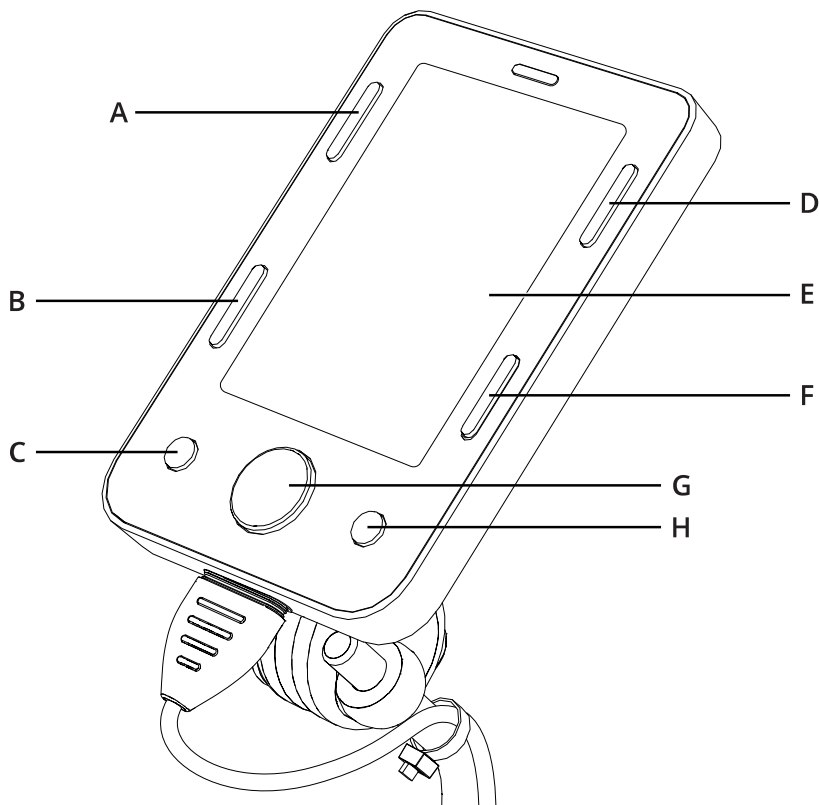

Your wheelchair can be equipped with an Omni2. An Omni2 is a device that makes it possible to operate the wheelchair with something other than a standard joystick.

Button configuration for Omni2.

- | | |
|---------------------|----------------------|
| A. On/off | E. LCD screen |
| B. Profile | F. Mode |
| C. Minus (-) | G. Navigation |
| D. Settings | H. Plus (+) |

For more information, see the user manual of your Omni2 on the website of Curtiss-Wright:



<http://support.pgdt.com/omni2-manual.pdf>

2.5 Lights and reflectors

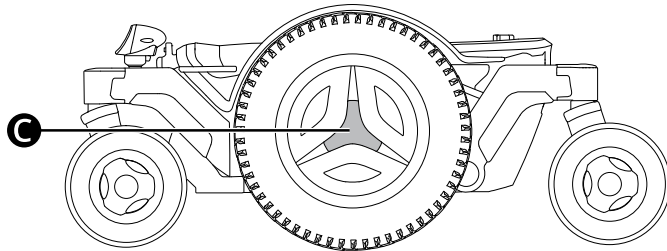
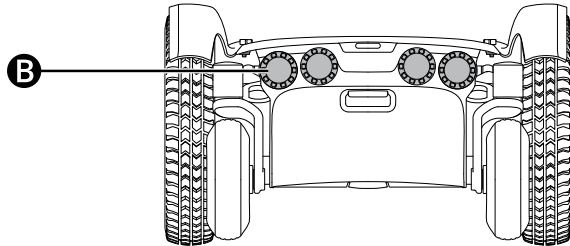
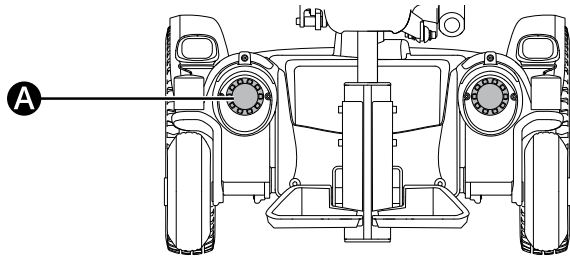

The wheelchair is equipped with reflectors at the front, the rear, and the sides.

Front lights, rear lights, and turn signals are optional.

- A** Front reflectors
- B** Rear reflectors
- C** Side reflectors

2.6 Wheels

A

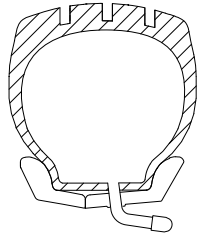
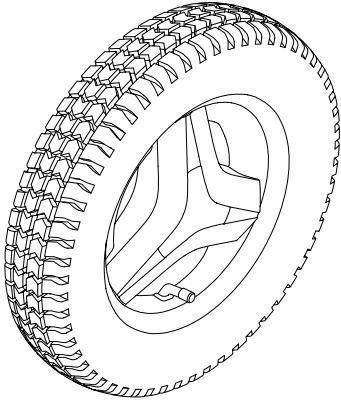

B

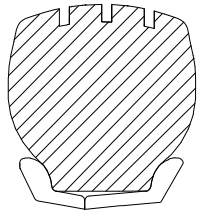
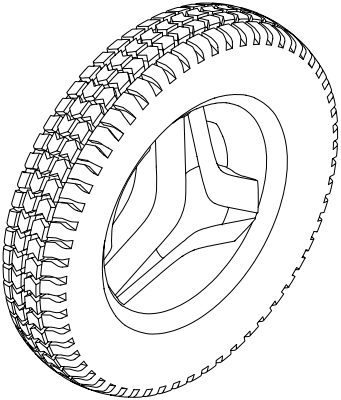





The wheelchair drive wheels have pneumatic tires or flat-free (foam filled) tires. The caster wheels have solid polyurethane tires.

- A** Pneumatic tires
- B** Flat-free (foam filled) tires

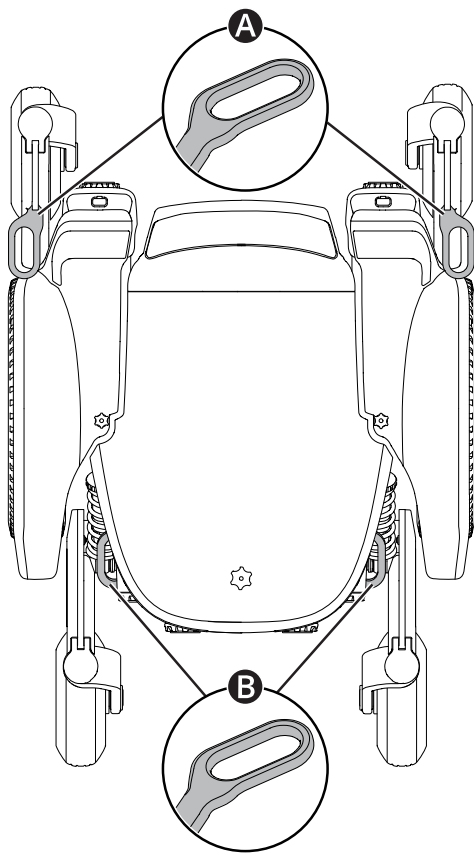
 Inflating the pneumatic tires. See page 60.

2.7 Tie-down points



The wheelchair is equipped with four tie-down points used for transportation   . Two in the front **A** and two in the rear **B**.

 Vehicle transportation. See page 29.

2.8 Serial number label

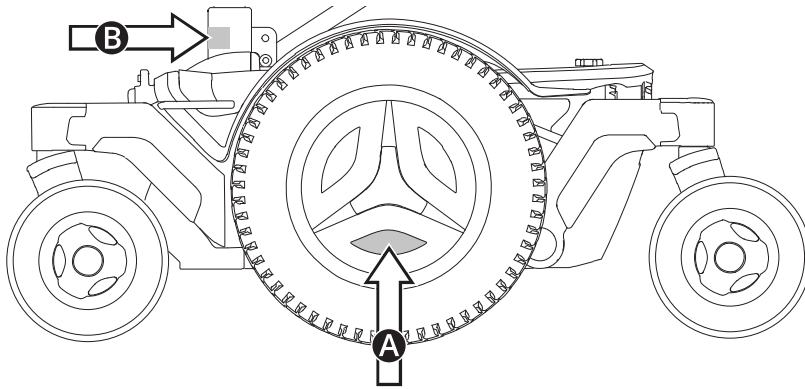

The serial number label is located on the lower, left side of the wheelchair chassis **A**. An additional serial number label is located on the seat tilt **B**. You may need to tilt the seat to see the serial number label.

The contents of the serial number label are described on page 21.

2.9 Accessories

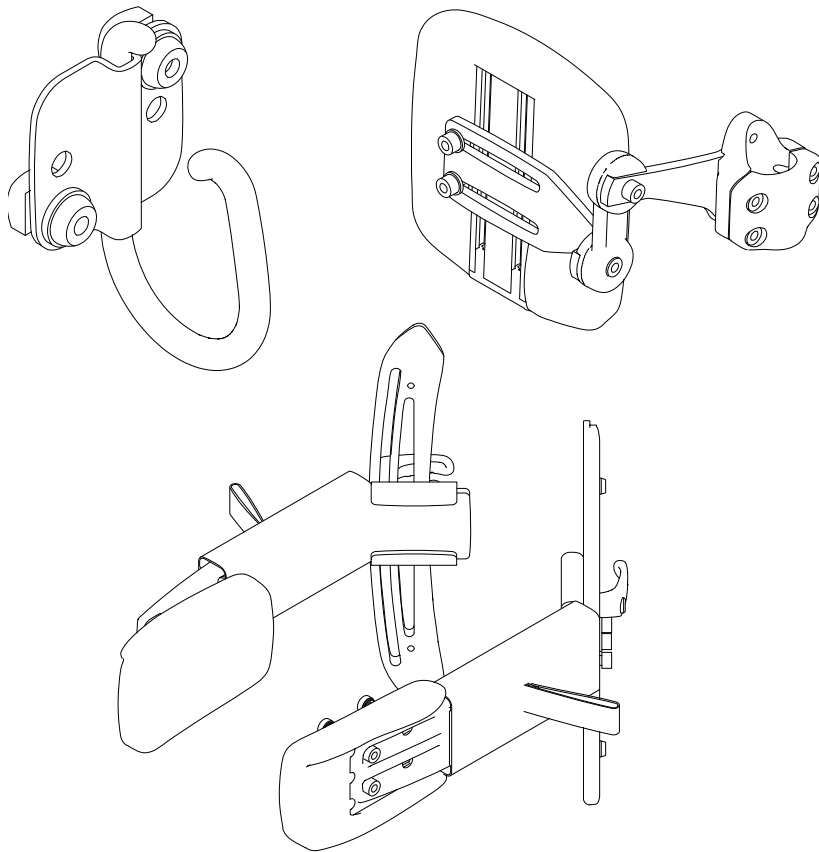

Accessories for Permobil products are subject to continuous development. Contact your nearest Permobil dealer for more information on the accessories available for your product. Only use accessories that are authorized by Permobil.

2.10 Spare parts

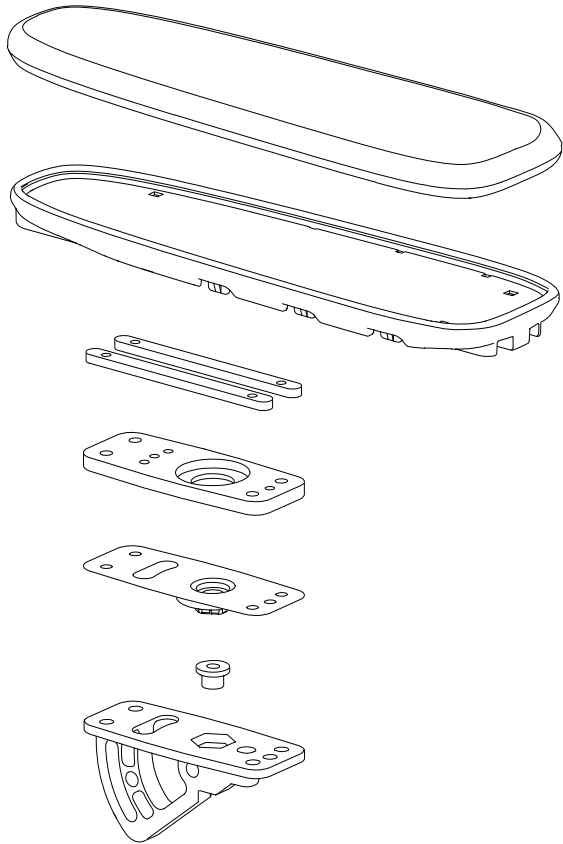

Spare parts must be ordered through your dealer.

Only use spare parts that are authorized by Permobil.

2.11 User manual

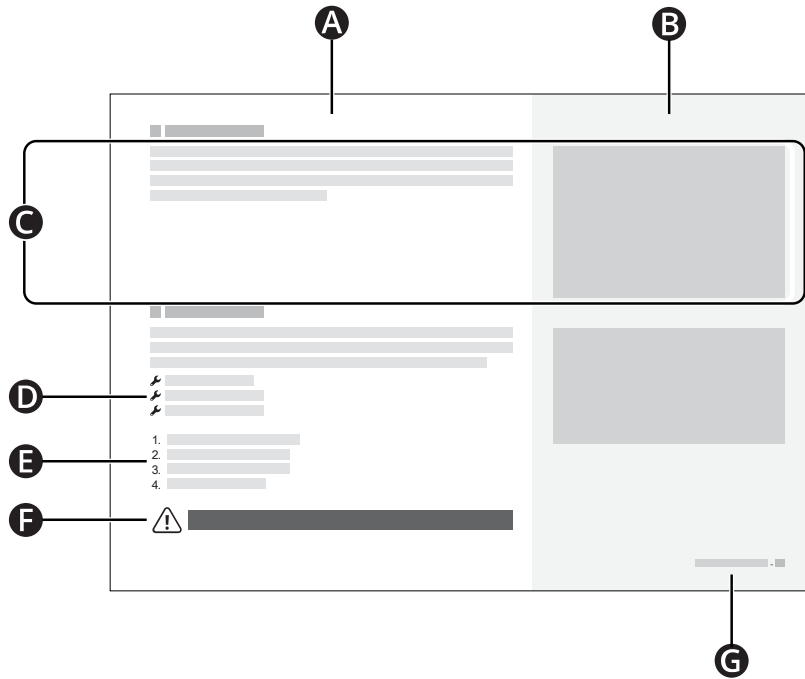

- A** Main text area
- B** Main illustration area
- C** Text correlates to the illustration to the right
- D** Tool list
- E** Instruction steps
- F** Warning sign
- G** Chapter and page number

3 Safety

Your wheelchair is a complex medical device and must be used safely. This chapter contains important information about how to safely use your wheelchair.

Permobil is not responsible for personal injuries or property damage resulting from any person's failure to follow the warnings and instructions in this user manual or from failure to exercise good judgment.

The following warnings are referenced throughout this user manual. Anytime you see the exclamation point symbol, refer back to this chapter to review the appropriate warning.

3.1 Types of warning signs

The following types of warning signs are used in this manual:



WARNING!

Indicates a hazardous situation which, if not avoided, could result in injury or death as well as damage to the product or other property.



CAUTION!

Indicates a hazardous situation which, if not avoided, could result in damage to the product or other property.



IMPORTANT!

Indicates important information.

3.2 Warning signs



WARNING! Follow the warnings and instructions

Follow the warnings and instructions in this user manual. If you do not, it can lead to bodily injury.



WARNING! Vehicle seating requirements

When you use the wheelchair as a seat in a vehicle, it must be forward-facing and you must use a three-point belt restraint, including a shoulder and pelvic belt, to reduce the risk of head and chest impacts with vehicle components. The wheelchair is only designed and tested for use in this configuration. If the wheelchair is used in another vehicle seating configuration, it can lead to bodily injury or death.



WARNING! Use tie-down points and docking systems properly

Make sure that you use tie-down points and docking systems properly. If you do not use them properly, it can lead to bodily injury or death.



WARNING! Pay attention to release mechanisms

Adjust your restraint system such that the release mechanisms cannot be pressed during a crash. If you do not, it can lead to bodily injury or death.



WARNING! Positioning aids do not replace seatbelts

Wheelchair positioning aids do not replace vehicle mounted seatbelts. In a traffic accident, they do not provide the same protection as vehicle mounted seatbelts. If you use positioning aids as a seatbelt, it can lead to bodily injury or death.



WARNING! Use positioning aids at all times

Use securely fastened positioning aids, including your positioning belt, at all times. If you do not, you can sustain bodily injuries.



WARNING! Do not overload the wheelchair

Do not use the wheelchair to pull any kind of object and never hang excessive weights on the wheelchair. If you do, the wheelchair can become less stable and injure you.



WARNING! Remain aware of your wheelchair's dimensions

Always remain aware of your wheelchair's dimensions. Some emergency exits or paths can be too small for your wheelchair to navigate through them.



IMPORTANT! Do not modify the wheelchair

Do not modify your wheelchair or any of its components. Your wheelchair has been configured specifically for your needs as prescribed by your healthcare provider. Special skills, training, and knowledge are needed to set up, modify, and repair the wheelchair.



WARNING! Avoid steep slopes

Do not drive the wheelchair on slopes steeper than 10°. If you do, the wheelchair can become less stable and injure you. For maximum performance and stability, use caution on slopes steeper than 6°.



WARNING! Use freewheel mode cautiously

Freewheel mode should only be used on level ground and when an attendant is present to control the wheelchair. If you use freewheel mode on an incline or without an attendant, you can get injured or cause property damage.



WARNING! Do not exceed the maximum user weight

Do not drive the wheelchair if you exceed the maximum user weight. If you do, the wheelchair can harm you or break.



WARNING! No passengers

Do not use the wheelchair to carry passengers, regardless of their age or weight. If you do, it can affect the wheelchair's maneuverability and stability.



WARNING! Drive extra carefully when lifted or tilted

If the seat or backrest is lifted or tilted on flat ground, drive at a low speed. If the seat or backrest is lifted or tilted, do not drive the wheelchair on slopes or over obstacles. If you do, the wheelchair can become less stable and injure you.



WARNING! Turn off the power

Turn off the power before you get in or out of the wheelchair or lift the armrest. If you do not, the wheelchair can move unintentionally and injure you.



WARNING! Do not use the wheelchair if it behaves abnormally or erratically

If the wheelchair is not behaving as it should, or if you suspect that something is wrong, stop the wheelchair as soon as possible, turn off the power and contact your service provider or Permobil for further information. If you use a wheelchair that behaves abnormally or erratically, it can lead to bodily injury.



IMPORTANT! Do not use a damaged wheelchair

If the wheelchair or its accessories have suffered transportation damage, damage during driving, or damage from other causes, you must inform Permobil as soon as possible and immediately stop using your wheelchair. There is a risk that the wheelchair or its accessories can no longer be used safely. Contact your service provider or Permobil for further information.



WARNING! Keep the electronics dry

Make sure that the electronics are not exposed to moisture. If any of the shrouds or the joystick boot have cracks or tears, replace them immediately. Exposure to moisture can cause the wheelchair to short-circuit or catch fire, which can lead to personal injury or property damage.



WARNING! Do not get pinched

The wheelchair is heavy and contains many moving parts, which means that you can be pinched when you adjust the wheelchair or if you use the wheelchair incorrectly. When you see this warning, be mindful of your body location to avoid being pinched. Do not put any part of your body between moving parts.



WARNING! Use leg rest tilt cautiously

Do not use the leg rest tilt when a knee support is in place. If you do, it can lead to bodily injury.



IMPORTANT! Recycle all batteries

Used batteries must be disposed of responsibly in accordance with local recycling regulations.



WARNING! Use the recommended tire pressure

Use the recommended tire pressure. If you overfill the tires, they can explode and cause bodily injury.



IMPORTANT! Electromagnetic fields

The electronics in a power wheelchair can be affected by external electromagnetic fields (for example mobile phones).



WARNING! Discontinue use after extraordinary events

Do not use your wheelchair if it has been dropped, crushed, exposed to fire, submerged in water, or involved in a vehicular accident, or other extraordinary events. Events like these can lead to significant damage that is impossible to detect upon inspection. Contact your service provider or Permobil. Damage caused by these types of incidents exceeds the limits covered by the manufacturer's warranty.







WARNING! Sufficient ground clearance

Always position the leg rest and footplate high enough so that they will not hit the ground when you drive your wheelchair. This includes when you drive over changing slopes or over obstacles. If you allow the leg rest or footplate to hit the ground, the wheelchair can become less stable and injure you.

3.3 Labels

Your wheelchair has labels that contain important information about safety and proper use. These labels are described in greater detail in this subchapter. Do not remove labels from the wheelchair. If a label becomes difficult to read or falls off, order a replacement from Permobil.

Serial number label

- A.  Serial number of the wheelchair
- B.  Maximum user weight
- C. Model: Model
- D. Link to patents
- E. Name and address of the manufacturer
- F. YYYY-MM-DD: Date of manufacture
- G.  CE mark
-  Medical device
- H. Unique Device Identification (UDI) as a GS1 DataMatrix including: date of manufacture and serial number

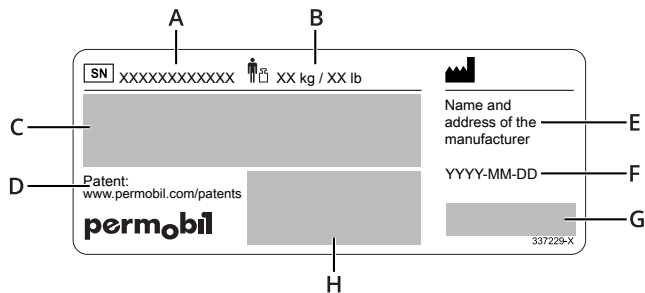

Warning

This label indicates that special attention is required.



Pinch risk

This label indicates a pinch risk. When you see this label, be extra careful to avoid pinching yourself or your belongings.



Main circuit breaker

This label shows the on and off positions for the main circuit breaker. Read more on page 34.



Freewheel mode

The picture to the left of the arrows indicates that the wheelchair is not in freewheel mode. The pictures to the right of the arrows indicate that the wheelchair is in freewheel mode. Read more about freewheel mode on page 28.



Tie-down points

This label shows the wheelchair's tie-down points. Read more about wheelchair transportation on page 29.



Conformance with ISO 7176-19

This label shows conformance with ISO 7176-19. See 4.5.2 *Using the wheelchair as a seat in a vehicle*.



Dahl docking station

If your wheelchair has been equipped with a lock plate for Dahl MK II or VarioDock, it will have this label. The lock plate is installed underneath the wheelchair.

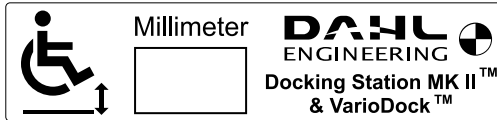

4 Wheelchair usage

This chapter aims to provide you with basic information to quickly get started with your wheelchair, and also provide you with information you may need in your everyday use of the wheelchair. The following subchapters describe how to drive the wheelchair, how to use the most common seat functions, how to charge the batteries, how to enter and exit freewheel mode, and some helpful information if you want to transport your wheelchair. They also describe the main circuit breaker, wheelchair storage, and manual adjustments.

4.1 Driving the wheelchair

You must always drive your wheelchair carefully and defensively. Your wheelchair is a complex medical device, not an automobile. Due to the individualized nature of Permobil products, your wheelchair is equipped with one of numerous different ways to drive it. The most common way is described below, but your wheelchair may not conform to this process depending on its individualization.

To drive your wheelchair, you must first turn on the power. The power button or switch is most commonly located on the wheelchair's control panel, which is usually attached to the armrest. Most Permobil wheelchairs also include a joystick on the control panel. Use this joystick to turn the wheelchair and to drive forward and rearward. Simply press the joystick in the direction you want to go **A**. The further you press the joystick, the faster the wheelchair will move. Release the joystick to stop moving.

Drive as gently as possible and avoid sudden braking. Do not turn off the power to stop the wheelchair. If you turn off the power while you drive, the wheelchair will stop abruptly.

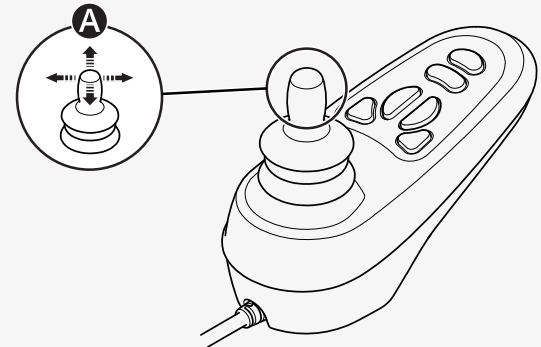

Do not move the joystick before, during, or immediately after you turn on the control system. If you move the joystick during this time, it can generate a joystick error. If this happens, turn off and then on the wheelchair.

For additional information on how to control your wheelchair, refer to any other documentation received with your wheelchair or contact your Permobil dealer.

Do not use the joystick as support when you get in or out of the wheelchair.

The first time you drive your wheelchair must be in the presence of a person who is qualified to ensure that the wheelchair is properly fit for you.

Make sure that your feet are correctly and securely positioned on the footplates before you drive the wheelchair.

4.1.1 Driving restrictions

The wheelchair consumes much power when you drive up a hill, climb over obstacles, or drive on rough terrain (for example sand). Permobil recommends that you, as far as possible, avoid to drive for a long period of time in these types of conditions.

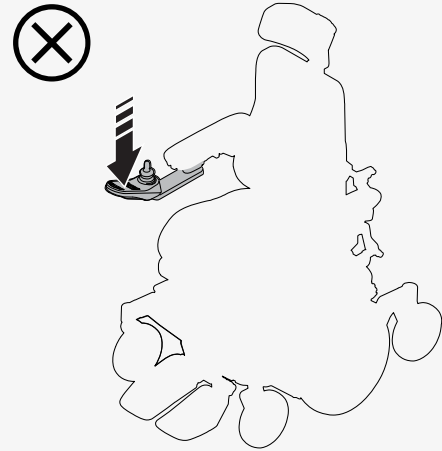

Permobil recommends that you do not use the wheelchair in extreme conditions, such as heavy rain, thick snow, or excessive heat or cold. Prolonged exposure to sunlight or cold temperatures can cause wheelchair surfaces to become very hot or cold. The driving range of your wheelchair is approximately 29 km (18 mi) when the battery temperature is 25°C (77°F). The driving range is affected by the battery temperature. Temperatures below 25°C (77°F) can shorten the driving range. Temperatures below -25°C (-13°F) can harm your batteries.

Do not use the wheelchair on stairs or escalators. Remember that alcohol can affect your ability to drive a power wheelchair. Do not let children drive the wheelchair without supervision.

This user manual's wheelchair specification states the wheelchair's maximum user weight. The stated user weight includes the user and any personal effects.

Avoid sudden stops and starts. Use caution in any of the following situations:

- when you are near edges or on elevated surfaces
- when you drive on soft or uneven surfaces, such as grass, gravel, sand, ice, or snow
- when you drive from an area of high traction (for example a sidewalk) to an area of low traction (for example grass)
- when you are in narrow or confined spaces
- when there are ridges that could cause the wheelchair to move in a different direction

When you drive over an obstacle, always directly face it. You can drive over obstacles up to 75 mm (3"). If you drive over higher obstacles, there is a greater risk of tipping and of damage to the wheelchair. If a car lock is installed on the wheelchair, it affects the ground clearance.



When you drive downhill, additional precautions must be taken. Select the lowest maximum speed and proceed with caution. Driving down a slope can shift your center of gravity forward. Release the joystick if the wheelchair rolls faster than you would like. This makes the wheelchair stop, and you can descend again more slowly. Avoid sudden stops and starts. Note that the distance required to stop will increase when you drive downhill.

Drive the wheelchair straight up slopes whenever possible.

4.2 Seat functions

Your wheelchair can have seat functions. A seat function is a power adjustment.

Due to the custom nature of Permobil products, your wheelchair is equipped with one of numerous different ways to adjust its seat functions. For additional information on how to control your wheelchair, refer to any other documentation received with your wheelchair or contact your Permobil dealer.

Permobil offers the following seat functions. Available functions can vary depending on the equipment fitted on your wheelchair.

- seat lift
- seat tilt
- backrest tilt
- leg rest tilt
- footplate lift

The wheelchair's center of gravity changes when you change the position of the seat and/or the backrest. When you lift or tilt the seat or backrest, you decrease the wheelchair's stability.





WARNING! Drive extra carefully when lifted or tilted

4.2.1 Seat tilt

The seat tilt tilts the entire seat, from headrest to leg rest. When the seat is tilted, the maximum speed of the wheelchair can be reduced automatically or the ability to drive the wheelchair can be restricted completely. The reduced maximum speed can be indicated with a turtle on the display of the control panel and by a yellow light on the switch box. The drive restriction can be indicated with a red light on the switch box or by a flashing turtle on the display of the control panel.

4.2.2 Leg rest tilt

The leg rest tilt tilts the leg rest.

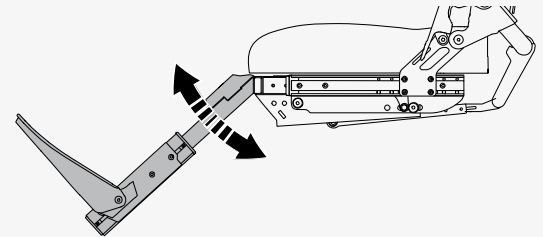
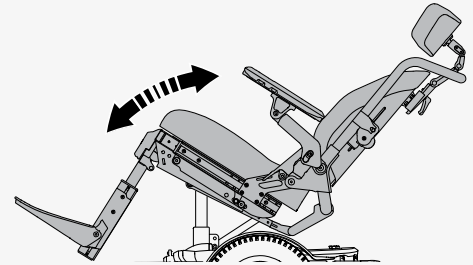

4.3 Charging the batteries

You can charge your wheelchair from the control panel. The charger socket is located at the front of the joystick. Always connect the charger to the wheelchair first before you connect the charger to the wall. It is not possible to drive the wheelchair while it charges.

Charge the wheelchair as often as possible. Do not use the wheelchair if the battery charge is low because you could become stranded. If the batteries become completely discharged, charge them immediately.

Only use a Permobil charger intended for use with your wheelchair. Charge the batteries in a well-ventilated, dry room. Never expose your batteries or any part of your wheelchair to an open flame.

For more information and further instructions, see the battery charger's manual that was supplied with your wheelchair or contact Permobil.

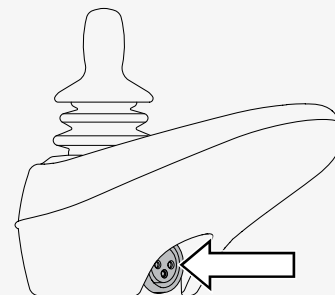

4.4 Freewheel mode

The wheelchair is fitted with two freewheel levers. When the freewheel levers are released, the wheelchair's brakes are disengaged from the motor. When in freewheel mode, the wheelchair can be moved manually, but cannot be controlled electronically.

When the wheelchair is in freewheel mode, it must not be possible to drive the wheelchair. If it can be driven, contact your service technician.



WARNING! Use freewheel mode cautiously

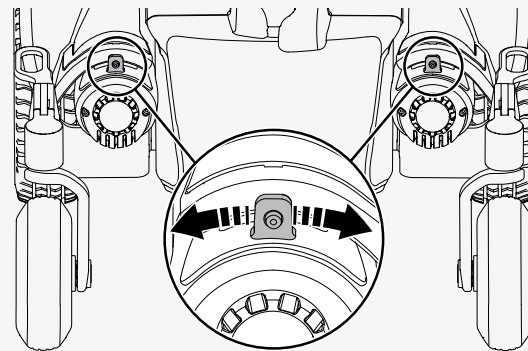

4.4.1 Entering freewheel mode

1. Make sure that the wheelchair is on level ground.
2. Turn off the wheelchair.
3. Flip both freewheel levers away from the center of the wheelchair.

4.4.2 Exiting freewheel mode

1. Turn off the wheelchair.
2. Flip both freewheel levers toward the center of the wheelchair.

4.5 Vehicle transportation

This chapter describes how you transport your wheelchair in a vehicle. The wheelchair must only be transported in wheelchair accessible vehicles.

4.5.1 Securing the wheelchair in a vehicle

This chapter describes how you secure the wheelchair in a vehicle. You must either secure the wheelchair at its tie-down points or use a docking system that complies with ISO 10542–1:2012, which is an international standard that governs wheelchair tie-downs and occupant-restraint systems.

Remove loose objects, trays, and other auxiliary equipment from your wheelchair and store them safely before you transport your wheelchair in a motor vehicle. If you transport a wheelchair in a motor vehicle with loose objects, trays, or other auxiliary equipment the vehicle's occupants could suffer bodily injury.

This is how you secure the wheelchair at its four tie-down points. Make sure that the wheelchair is properly secured and that the wheelchair is not in freewheel mode. Secure the wheelchair with straps at the tie-down points at the front and rear. The tie-down points are marked with yellow labels **A**. Use heavy-duty straps when necessary.

After you have secured the straps to your wheelchair, secure the other end of the straps to your vehicle according to the appropriate instructions. The end-fitting on the strap must comply with ISO 10542-1:2012, which is an international standard that governs wheelchair tie-downs and occupant-restraint systems. Every vehicle tie-down system is different, and it is important that you follow the instructions for your particular vehicle system.

To make transportation of the wheelchair easier, you can remove or fold down the backrest. This is done in a few simple moves. See page 39. If necessary, you can also remove the headrest. See page 35.

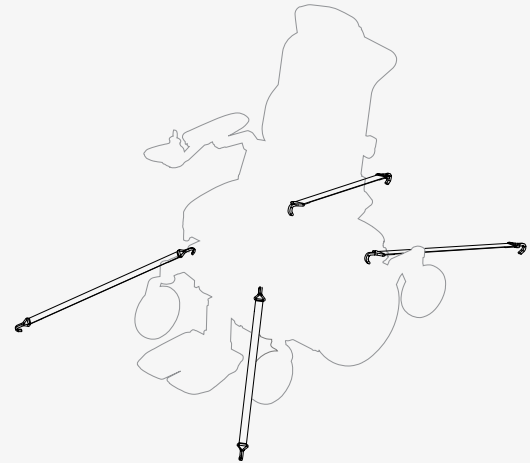
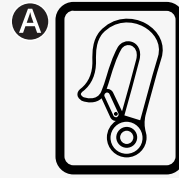

You can also use a docking system to secure your wheelchair. The Dahl docking stations MK II and VarioDock are approved docking systems. The maximum user weight for Dahl docking stations is 136 kg. See the docking station's manual on how to operate it.

For service technicians who install lock plates, find the relevant assembly instruction here: <https://refs.permobil.com/IFU/332849>



4.5.2 Using the wheelchair as a seat in a vehicle

Permobil recommends that, whenever feasible, you transfer to a vehicle seat and that you use the vehicle's restraint systems. The unoccupied wheelchair should be stored in a cargo area or secured in the vehicle during travel. Follow the instructions below if you want to use the wheelchair as a seat in a vehicle.



WARNING! Positioning aids do not replace seatbelts



WARNING! Vehicle seating requirements

The wheelchair shall be forward-facing when you use it as a seat in a vehicle. Permobil has no manufacturer-designated wheelchair-mounted belt restraints. Use the vehicle's restraint systems.

You must use both pelvic-belt restraints and shoulder-belt restraints. Pelvic- and shoulder-belt restraints should be used together as designed.

Make sure that the belt restraints are as tight as possible, without becoming uncomfortable, and that they are not twisted. They must be close to your body and not held away by parts of the wheelchair. Adjust your restraint system such that the release mechanisms cannot be pressed during a crash.

The shoulder-belt restraint should be worn over the middle of the shoulder. The pelvic-belt restraint should be in contact with and worn low across the pelvis and within the preferred zone of 30° to 75°. A steeper pelvic-belt angle between 45° to 75° to the horizontal is preferred. Make sure that no components of the wheelchair are lifted or tilted. The wheelchair must be in the position shown in the image.

4.6 Air transportation

This chapter contains information that can be helpful if you are transporting your wheelchair by air.

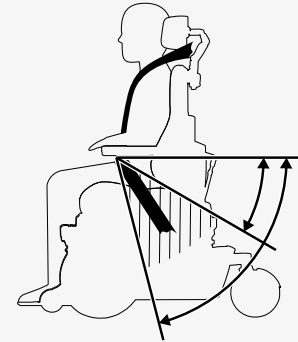
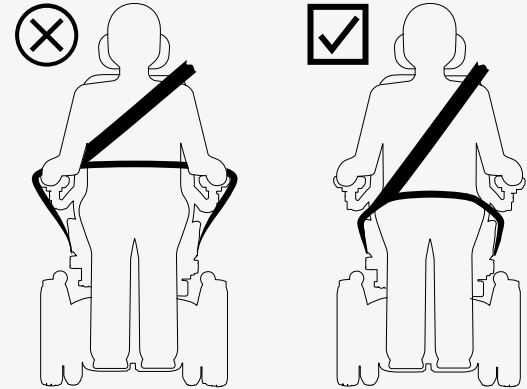

4.6.1 Batteries

The main circuit breaker must always be in the off position. In most cases, gel batteries do not have to be removed from the wheelchair.

4.6.2 Weight and dimensions

Contact the relevant airline for applicable rules on weight and dimensions for your power wheelchair.

4.6.3 Preventing damage to wheelchair

Since the wheelchair will be put with other goods in a confined space during the flight, it is important to take preventive measures to minimize transportation damage to the wheelchair.

Cover the control panel and other sensitive objects with soft, shock-absorbing material (foam plastic or similar). Push the control panel toward the backrest. Tape any loose cables to the seat or covers.

4.7 Main circuit breaker

Your wheelchair has a main circuit breaker with two functions. You can use it to turn off the main power, for example before you transport the wheelchair. It also trips if there are any issues with the circuits.

The first time the main circuit breaker trips, you can reset it yourself. If it trips again, contact your service technician.

Use the lever at the back of the wheelchair to turn on and off or to reset the main circuit breaker. Always turn off the control panel before you turn off the main circuit breaker.

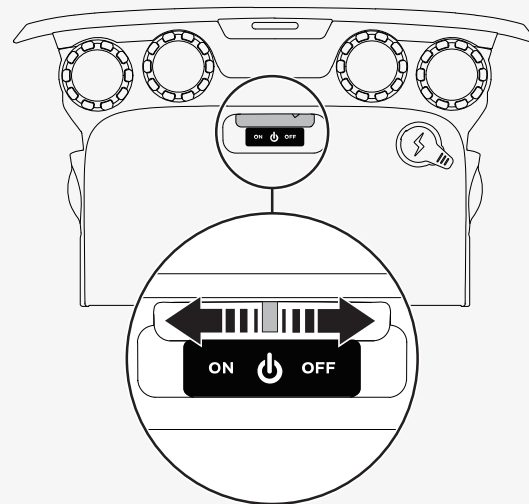

4.8 Wheelchair storage

You can store your wheelchair for a short or long period of time.

When you store it for a short time, make sure that the room is dry and at least 5°C (41°F). If the temperature is lower, the batteries might not charge fully. They are also more vulnerable to corrosion.

When you store it for a long time, fully charge the batteries before storage. Remember to switch off the main circuit breaker. Charge the batteries every month. You will need to switch on the main circuit breaker to charge the batteries, then switch off the main circuit breaker if the wheelchair is to remain in storage.

4.9 Manual adjustments

The wheelchair can have functions that are adjusted manually. Available functions vary depending on the equipment fitted on your wheelchair.

If you do not have the power lift function on your wheelchair, seat height must only be adjusted by authorized service providers.

4.9.1 Headrest with link hardware

This chapter shows you how to adjust the height, depth, and angle of the headrest. It also shows you how to remove and install the headrest.

This is how you adjust the height of the headrest. There are four different height settings on your headrest. Setting **A** is the lowest and setting **B** is the highest. If setting **A** is used, test the seat functions seat tilt and backrest tilt for interference.

🔑 Allen key 2.5 mm

1. Follow the instructions below to remove the headrest.
2. Remove the screw and put it in the preferred setting on the bracket.
3. Follow the instructions below to install the headrest.

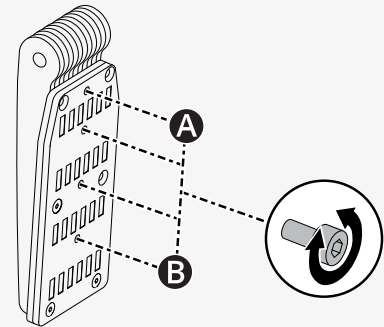

This is how you adjust the height and depth of the headrest.

🔧 Allen key 5 mm

1. Loosen the screw at each link **A**.
2. Change the angle of the links as required.
3. Tighten the screws.

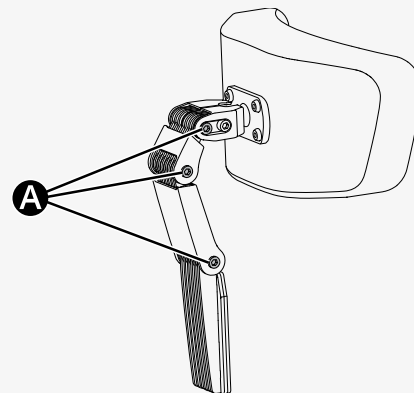

This is how you adjust the angle of the headrest.

🔧 Allen key 5 mm

1. Loosen the front screw **A** in the top link.
2. Adjust the headrest angle to the preferred position **B**.
3. Tighten the screw.

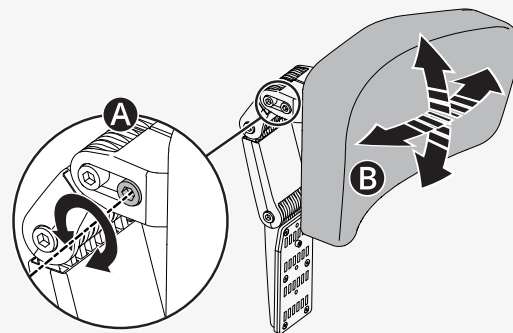

This is how you remove and install the headrest.

1. Loosen the handle **A** at the rear of the backrest.
2. Lift the headrest straight up **B**.

Install in the reverse order. You can remove and install the headrest without affecting current settings.

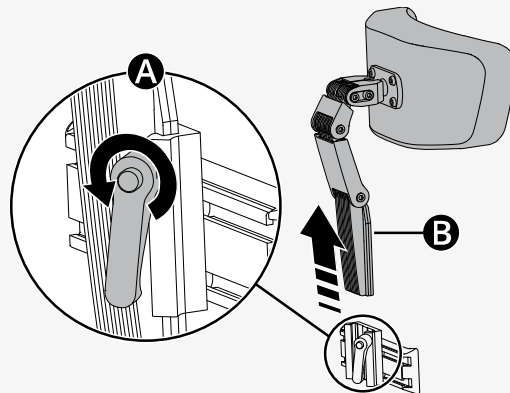

4.9.2 Backrest

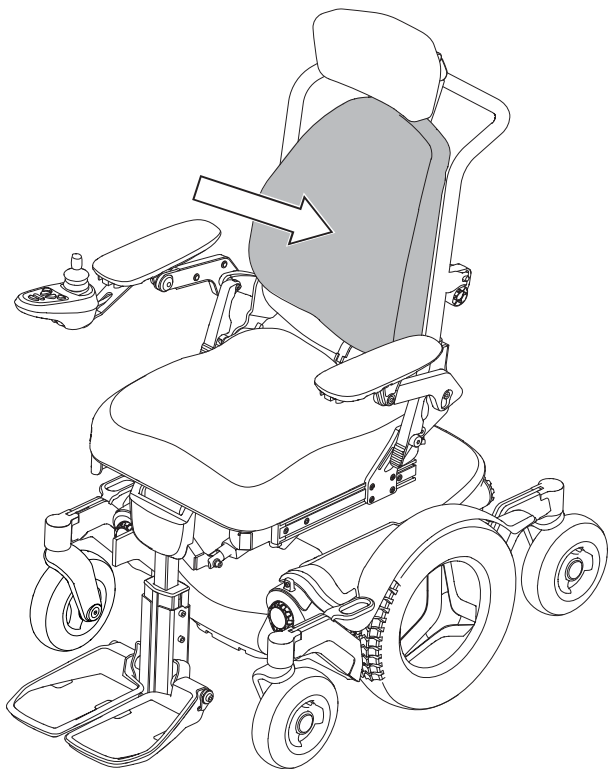

This chapter shows you how to fold down the backrest, and how to adjust the backrest frame angle.

4.9.2.1 Folding down the backrest

If your backrest has a manual quick release, you can fold down the backrest in a few steps.



WARNING! Do not get pinched

This is how you fold down a backrest with a manual quick release.

1. Remove the backrest cushion if needed.
2. Make sure that the armrests are unlocked. See page 44.
3. Hold the backrest so that it does not fall forward.
4. Push the manual quick release button **A**.
5. Pull out the lock pin.
6. Make sure that you do not pinch or stretch any cables and fold the backrest forward **B**.

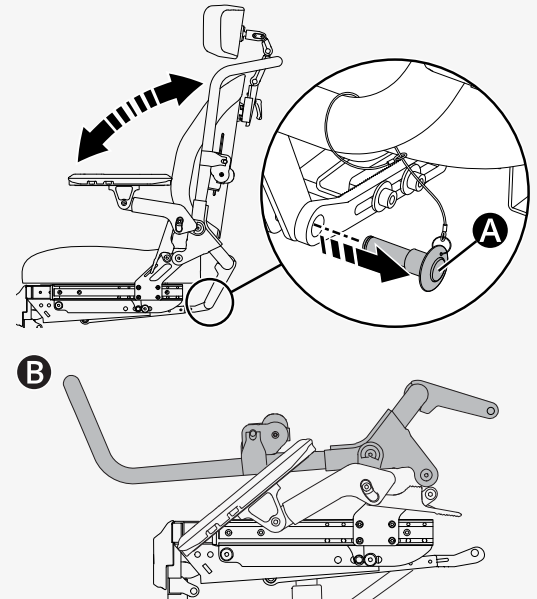

4.9.2.2 Folding up the backrest

If your backrest has a manual quick release, you can fold up the backrest in a few steps.



WARNING! Do not get pinched

This is how to fold up the backrest with a manual quick release.

1. Make sure that you do not pinch or stretch any cables and fold up the backrest **A**.
2. Hold the backrest so that it does not fall forward.
3. Press the button **B** on the lock pin when you push it through the holes.

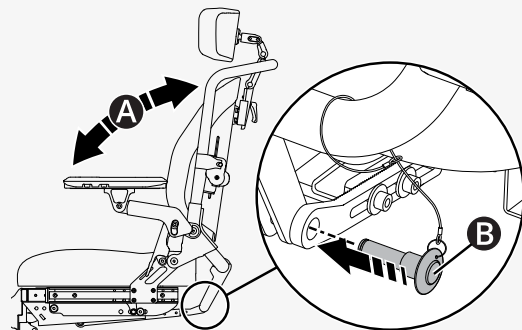

4. Make sure that the lock pin has clicked into place. Check that the lock mechanism is out and that the lock pin cannot be pulled out.
5. Lock the armrests. See page 44.

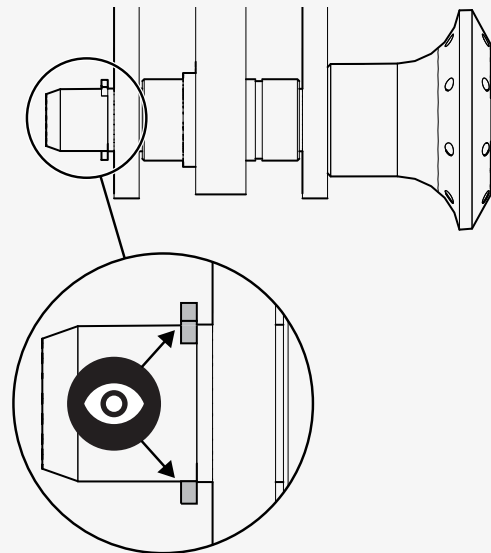

4.9.2.3 Manual backrest tilt

You can tilt the backrest.

- 🔧 Torque wrench
- 🔧 Allen socket 5 mm

1. Hold the backrest so that it does not fall forward.
2. Loosen screws **A** and **B**.
3. Adjust the backrest to the preferred angle **C**.
4. Torque the screws to 9.8 N m (7.2 lb. ft.).
5. Make sure that the backrest is locked in position.

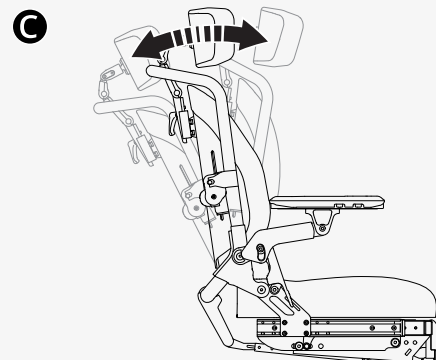
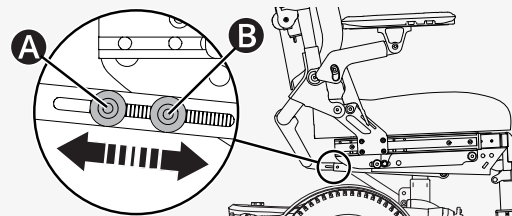

4.9.3 Armrest

This chapter shows you how to adjust the height and the angle of the armrest, how to adjust the armrest pad, and how to fold up the armrest.

4.9.3.1 Height

You can adjust the height of the armrest.

- 🔧 Torque wrench
- 🔧 Allen key 6 mm

1. Loosen the screw **A**.
2. Adjust the armrest to the preferred height.
3. Torque the screw **A** to 9.8 N m (7.2 lb. ft.).

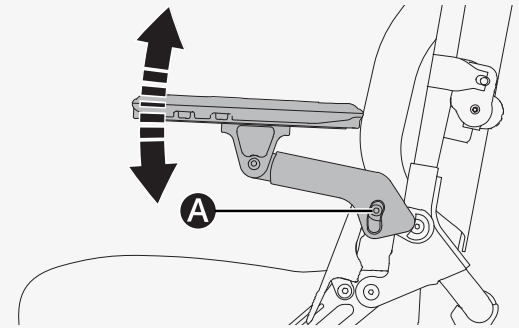

4.9.3.2 Angle

You can adjust the angle of the armrest.

- 🔧 Torque wrench
- 🔧 Allen key 6 mm

1. Loosen the screw **A**.
2. Adjust the armrest to the preferred angle.
3. Torque the screw **A** to 9.8 N m (7.2 lb. ft.).

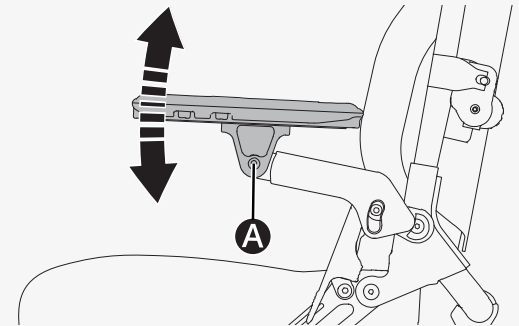

4.9.3.3 Armrest pad

You can adjust the armrest pad.

- 🔧 Torque wrench
- 🔧 Allen key 5 mm

1. Loosen the four screws **A** under the armrest.
2. Slide the armrest pad to the preferred position.
3. Use a torque wrench to torque the screws **A** to 9.8 N m (7.2 lb. ft.).

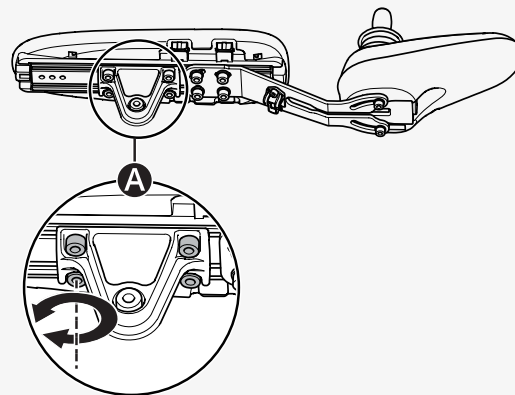

4.9.3.4 Folding up the armrest

You can unlock and fold up the armrest.

1. Pull the lever **A** rearward.
2. Fold up the armrest.

When you have folded down the armrest, push the lever forward to lock the armrest again.

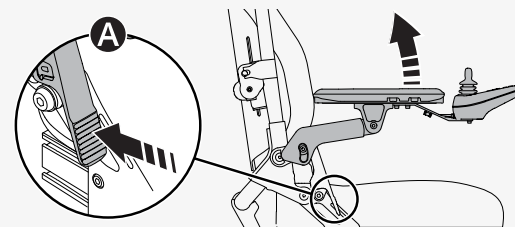

4.9.4 Manual leg rest

This chapter shows you how to adjust the angle on a manual leg rest. The leg rest can be adjusted and locked in a number of fixed positions. If the seat depth is 510–560 mm (20"–22"), you can adjust the leg rest angle from 80° **B** to 135° **A**. If the seat depth is 335–480 mm (14"–19"), leg rest angle **B** is 87.5°.

This is how you adjust the angle of a manual leg rest.

1. Pull out and hold the lock lever **A** to release the leg rest.
2. Adjust the leg rest to the preferred angle.
3. Release the lock lever **A**.
4. Make sure that the lock lever is in a locked position.

4.9.5 Swing away leg rest

This chapter shows you how to adjust the angle of the swing away leg rest.

When you drive the wheelchair, you must position the leg rest such that it will not interfere with the caster wheels when they swivel. As you drive, the caster wheels will swivel in all directions.

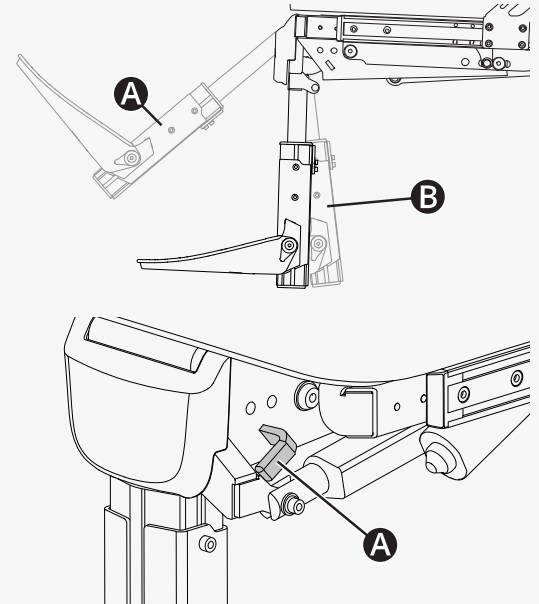

This is how you adjust the angle of the leg rest.

🔧 Torque wrench

🔧 Allen key 5 mm

1. Loosen screws **A** and **B**.
2. Adjust the leg rest to the preferred position.
3. Torque screws **A** and **B** to 9.8 N m (7.2 lb. ft.).
4. Make sure that the leg rest is secured.

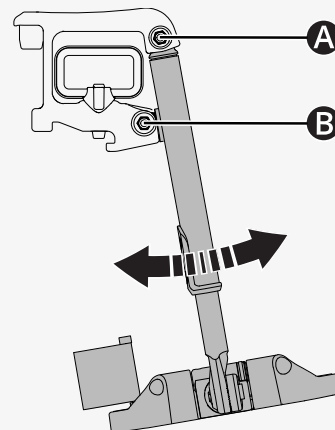

4.9.6 Footplate on a power leg rest

You can adjust the angle and height of the footplates on a power leg rest. The angle is adjusted in the same way as on a manual leg rest. See below.

Make sure that the outer profile does not touch or collide with the actuator arm. If it does, adjust the web belt when the leg rest is in its most vertical position.

This is how you adjust the height of the footplates.

🔧 Torque wrench

🔧 Allen key 3 mm

1. Loosen the two screws that hold the web belt bracket **A** in place.
2. Release the web belt on the rear of the leg rest.
3. Move the leg rest to its most vertical position.
4. Push up the outer profile that the footplates are installed to.
5. Adjust the web belt so that the gap **d** between the outer profile and the actuator arm is 2–10 mm (0.1"–0.4").
6. Tighten the web belt.
7. Run the leg rest to the horizontal position and back to the vertical position.
8. Check the gap **d**.
9. Torque the screws to 2.9 N m (2.1 lb. ft.).
10. Make sure that the footplates are secured.

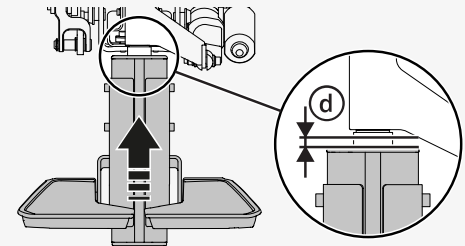
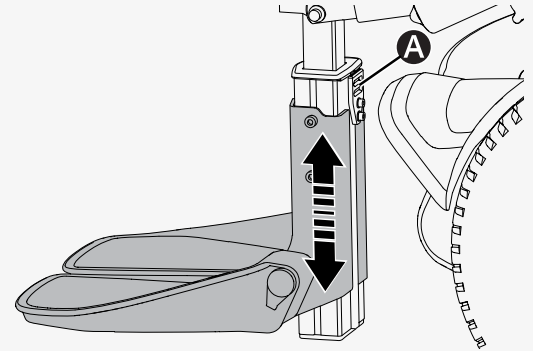

4.9.7 Footplate on a manual leg rest

You can adjust the angle and the height of a footplate on a manual leg rest.

This is how you adjust the angle of the footplate.

🔧 Wrench 10 mm

🔧 Allen key 5 mm

1. Tilt up the footplate.
2. Loosen the lock nut **A**.
3. Adjust the stop screw **B** in or out until the footplate has the preferred angle.
4. Tighten the lock nut **A** to lock the stop screw in the preferred position.

This is how you adjust the height of the footplates. You can adjust the height of each footplate individually.

🔧 Torque wrench

🔧 Allen key 5 mm

1. Loosen the two screws **A**.
2. Adjust the footplate bracket to the preferred height.
3. Torque the two screws **A** to 9.8 N m (7.2 lb. ft.).
4. Make sure that the footplate is secured.

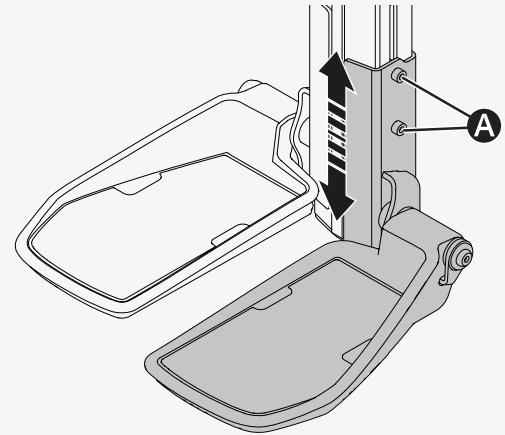
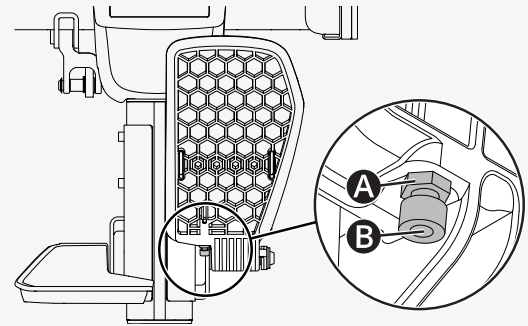

4.9.8 Footplate on a swing away leg rest

This chapter shows you how to adjust the horizontal angle, the vertical angle, and the height of a footplate on a swing away leg rest.

When you drive the wheelchair, you must position the leg rest such that it will not interfere with the caster wheels when they swivel. As you drive, the caster wheels will swivel in all directions.

This is how you adjust the horizontal angle of the footplate.

🔑 Allen key 6 mm

1. Fold up the footplate.
2. Loosen the screw **A**.
3. Adjust the angle of the footplate.
4. Torque the screw **A** to 24 N m (17.7 lb. ft.).

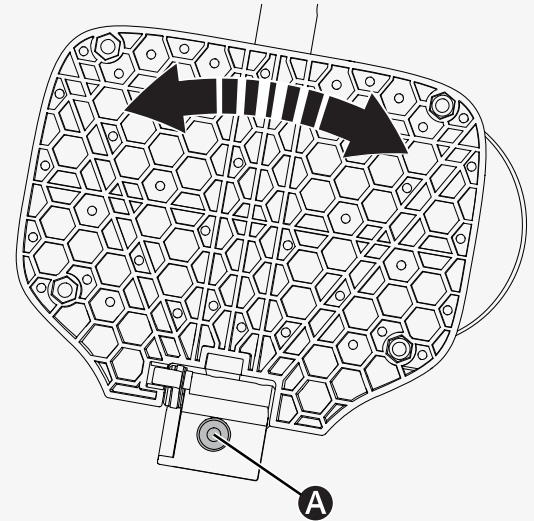

This is how you adjust the vertical angle of the footplate.

🔧 Torque wrench 10 mm

🔧 Allen key 6 mm

1. Loosen the screw **A**.
2. Adjust the angle of the footplate.
3. Torque the screw **A** to 24 N m (17.7 lb. ft.).

This is how you adjust the height of the footplate.

🔧 Torque wrench

🔧 Allen key 3 mm

1. Loosen the screws **A**.
2. Adjust the height to the preferred position.
3. Torque the screws **A** to 7.4 N m (5.5 lb. ft.).

4.9.9 Fixed panel holder

The fixed panel holder can be installed on either armrest.

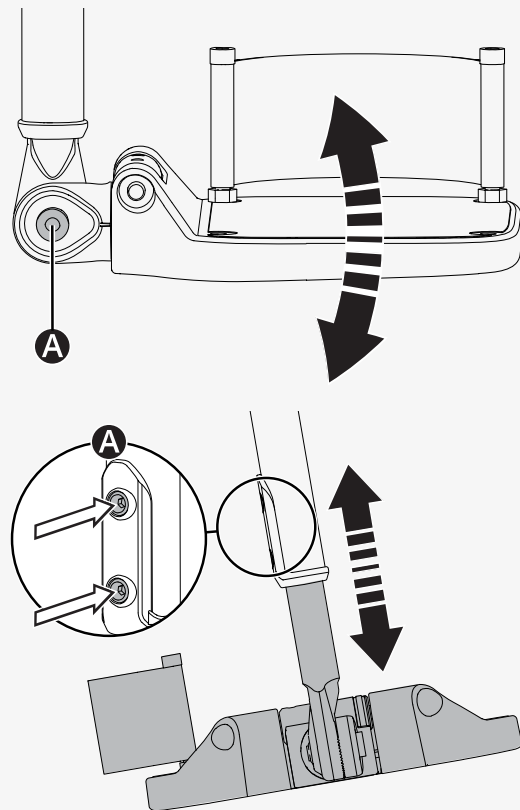

You can adjust the distance between the armrest and the control panel. It is also possible to adjust the angle of the control panel.

This is how you adjust the distance between the armrest and the control panel.

- 🔧 Torque wrench
- 🔧 Allen key 4 mm
- 🔧 Allen key 5 mm

1. Loosen the four screws **A** on the panel joint and slide the panel to the preferred position.
2. Torque the screws to 9.8 N m (7.2 lb. ft.).

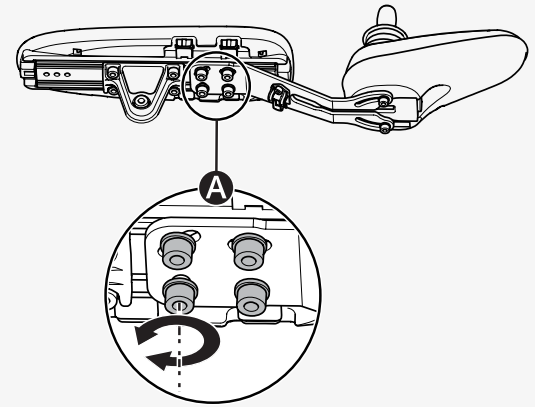

This is how you adjust the angle of the control panel.

1. Loosen the four screws **A** on the panel joint and the two screws **B** under the control panel.
2. Adjust the angle to the preferred position.
3. Torque the screws to 2.9 N m (2.1 lb.ft.).

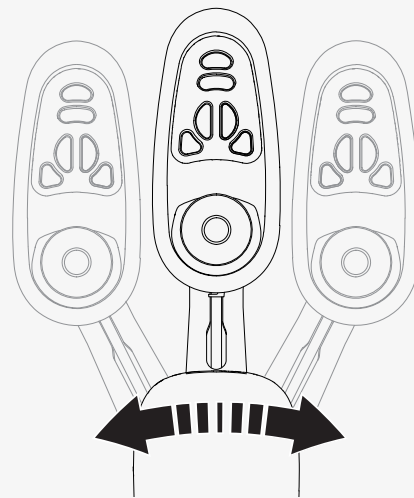
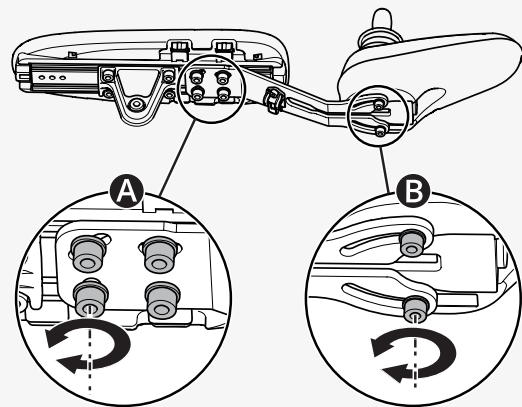

4.9.10 Parallel panel holder

You can adjust the distance between the armrest and the control panel. It is also possible to adjust the angle of the control panel.

This is how you adjust the distance between the armrest and the control panel. Leave a gap of at least 10 mm (0.4") between the armrest and the control panel.

- 🔧 Torque wrench
- 🔧 Allen key 5 mm

1. Loosen the screws **A** enough to slide the panel holder.

2. Adjust the panel to the preferred position.
3. Torque the screws to 9.8 N m (7.2 lb. ft.).

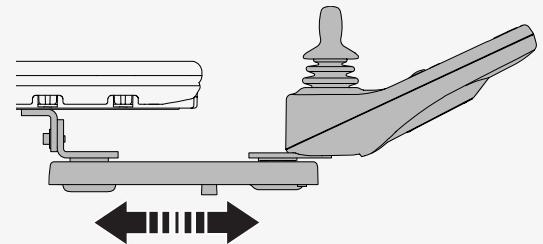
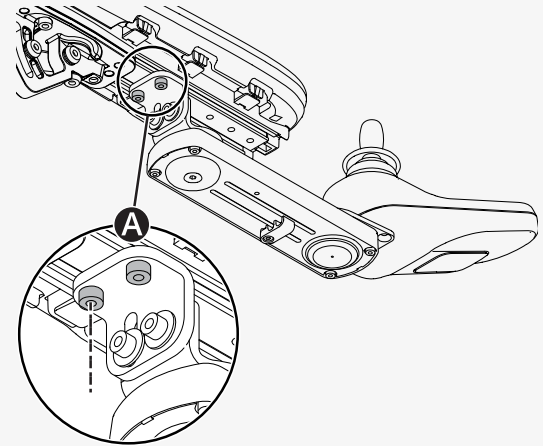

This is how you adjust the angle of the control panel.

🔑 Allen key 4 mm

Slide the panel to the preferred position. You can loosen or tighten the screw

Ⓐ to adjust the resistance.

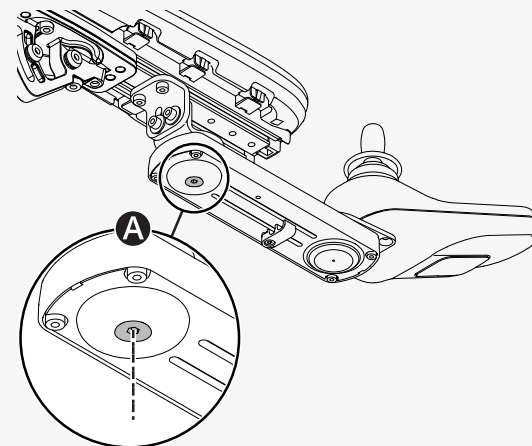
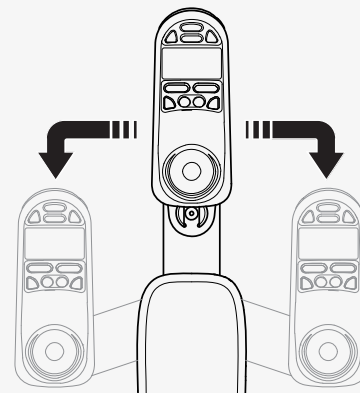

4.9.11 Positioning belt

Always wear your positioning belt. There is an accessory rail on each side of the seat frame where you can attach for example a positioning belt.

🔧 Wrench 10 mm

1. Screw the positioning belt in place in the rail's upper groove.
2. Make sure that the belt buckle locks properly in the snap lock.

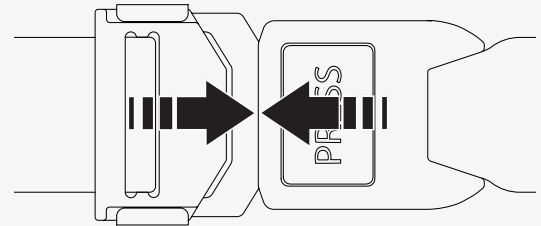
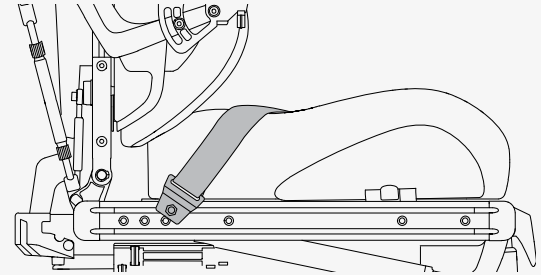

5 Maintenance

For the wheelchair to work well, it is important that you use it correctly and maintain it regularly. A well maintained wheelchair lasts longer and has a lower risk of defects. Only carry out maintenance and minor adjustments that are specified in the user manual. All other maintenance, service, and repairs must be carried out by a qualified service technician authorized by Permobil.

5.1 Maintenance and inspection schedules

Permobil recommends compliance with the following maintenance and inspection schedule. Contact your authorized dealer for all service-related needs or questions.

Maintenance and inspection schedule	Daily	Weekly	Monthly	Yearly
Check battery level indicator and charge the wheelchair if necessary.	×			
Make sure that the joystick panel and other control panels are not damaged.	×			
Make sure that all removable parts are securely fastened.	×			
Check positioning belts for wear and make sure buckles work.	×			
If the wheelchair is equipped with pneumatic tires, check tires and inflate as necessary.		×		
If the wheelchair is equipped with lights and turn signals, make sure that they are operational and clean.		×		
Clean the wheelchair and upholstery.			×	
Check upholstery, seating, and postural supports for wear.			×	
Check that the freewheel mode and the freewheel lever work properly.			×	
Complete inspection, safety check, and service performed by an authorized wheelchair dealer.				×

5.2 Cleaning

Regular care and maintenance will prevent unnecessary wear and damage to your Permobil product. Turn off the power before you clean the wheelchair.

5.2.1 Metal surfaces

Due to the high quality powder coating, optimum corrosion protection is guaranteed. Ideally, use a soft cloth or sponge, hot water, and a mild detergent for normal cleaning. Wipe down carefully with a cloth and water, and dry off.

Remove scuff marks from semi-matte surfaces with soft wax. Follow the instructions provided by the manufacturer of the soft wax.

Remove scuff marks and scratches from shiny surfaces with car polish. You can use either liquid or paste car polish. After you have polished, apply soft car wax to restore the original surface gloss.

5.2.2 Plastics

For normal cleaning, wash plastic surfaces with a soft cloth, mild detergent, and hot water. Rinse thoroughly and dry with a soft cloth. Do not use solvents or abrasive kitchen cleaners.

5.2.3 Upholstery, cloth, and vinyl

For normal cleaning, wash the upholstery with lukewarm water and a mild, non-abrasive soap. Use a soft cloth or brush. Wipe off any water or soapy water residues with a clean, dry cloth. Let the surface dry. Repeat this procedure to remove stubborn dirt or stains. Ink spots can sometimes be removed with soap and water followed by isopropyl alcohol.

Do not use any other cleaning methods than those listed here. Other cleaning methods can attack and degrade the vinyl and can also void the wheelchair's warranty.

If necessary, you can remove the cover before cleaning. See also the washing instructions on the upholstery materials.

5.2.4 Control panel

Use a soft cloth moistened with mild detergent; be careful when cleaning the joystick and the panel display. Do not use solvents or abrasive kitchen cleaners. The panel must not be rinsed with water or any other liquid.

5.2.5 Corrosion protection

The plastic and padded parts are corrosion resistant. The metal parts are protected against corrosion by a zinc layer underneath the powder coating.

5.3 Inflating the drive wheel tires

Only drive the wheelchair with the correct tire pressure. The tire pressure for the drive wheel tires is 250 kPa (35 psi). Permobil recommends that you check the tire pressure weekly and after any significant change in temperature or altitude.

Incorrect tire pressure can make the wheelchair unstable and difficult to drive. It can also result in abnormal wear, punctures, a shorter driving range, and damage to the wheel assembly.

This is how you inflate the drive wheel tires.

1. Unscrew and remove the valve cap from the tire air valve.
2. Connect the compressed air nozzle to the valve and adjust the tire pressure to the prescribed level.
3. Put the valve cap back.

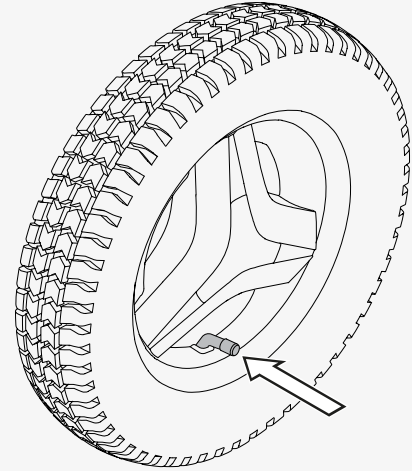

5.4 Positioning belt

Check the condition of the positioning belt regularly in case any damage or wear has occurred. If signs of damage or wear appear, replace the positioning belt immediately through your Permobil dealer.

6 Troubleshooting

The following troubleshooting guide describes a number of faults and events which can occur when you use the wheelchair, together with suggested remedies.

Note that the guide cannot describe all the problems and events which may occur and you should always contact your service provider or Permobil technical support if you need additional assistance. Troubleshooting and repairs of electronics must always be performed by qualified personnel with good knowledge of the wheelchair's electronics.

Event	Possible cause	Remedy
The wheelchair does not start.	The batteries are discharged.	Charge the batteries.
	The cable connection to the control panel has come loose.	Insert the cable in the control panel.
	The main circuit breaker is turned off.	Turn on the main circuit breaker. See page 34.
	The main circuit breaker has tripped.	Reset the main circuit breaker once. See page 34.
The wheelchair cannot be charged.	The main circuit breaker is turned off.	Turn on the main circuit breaker. See page 34.
	The charging circuit breaker has tripped.	Wait five minutes. The charging circuit breaker will automatically reset.

Event	Possible cause	Remedy
The wheelchair cannot be driven.	The battery charger is connected.	Disconnect the battery charger.
	The wheelchair is in freewheel mode.	Exit freewheel mode and restart the wheelchair.
	The wheelchair is locked.	Unlock the wheelchair.
	A seat function has triggered the automatic drive inhibit.	Make sure that the backrest and the leg rest are not tilted and that the seat is not tilted or lifted.
	The motors have gotten too warm.	Turn off the wheelchair and wait for the motors to cool down.
The wheelchair switches itself off after a certain period of inactivity (20–30 minutes).	The energy saving mode has been activated.	Press the start button on the control panel to turn on the wheelchair again.
The wheelchair stops while being driven.	The main circuit breaker has tripped.	Reset the main circuit breaker once. See page 34.
The wheelchair can only be driven at reduced speed.	A seat function has triggered the automatic speed restriction.	Make sure that the backrest and the leg rest are not tilted and that the seat is not tilted or lifted.

7 General information

This chapter contains information about warranty, standards and regulations, reporting incidents, scrapping and recycling, and technical specifications.

7.1 Warranty

Contact your dealer or Permobil Inc. USA for information about the warranty period for this product.

Product Warranty Information sets forth the conditions of the warranty. For further information about applicable warranties, see <https://permobilus.com/support/warranties/>.

7.2 Standards and regulations

This product fulfills the following requirements:

- Electrically powered wheelchairs, scooters and their chargers – Requirements and test methods (EN 12184)
- Wheelchair standard series ISO 7176
- U.S. Food and Drug Administration's regulation 21 CFR 820
- Medical Device Regulation (EU) 2017/745

7.3 Reporting incidents

If a serious incident occurs, you must contact a competent authority and Permobil by phone or e-mail.

7.4 Scrapping and recycling

Contact Permobil for information about scrapping agreements in force.

7.5 Technical specifications

Mass of the heaviest part	Backrest 2.7 kg (6 lb.)
Pivot width	1340 mm (53")
Minimum turning diameter	1340 mm (53")
Required width of angled corridor	1210 mm (48")
Required doorway entry depth	1520 mm (60")
Required corridor width for side opening	1050 mm (41")
Ground clearance	80 mm (3")
Ability to negotiate obstacles (approach distance 0 cm [0"])	50 mm (2")
Ability to negotiate obstacles (approach distance 50 cm [20"])	75 mm (3")
Battery cycle life	450 cycles
Battery type and nominal voltage	Sealed lead acid, 2 x 12 V, group 34
Occupant mass group	III
Maximum speed (forward on horizontal)	8 km/h (5 mph)
Theoretical continuous driving range ¹	29 km (18 mi)

1. Actual driving range will vary based on driving conditions, battery conditions, and terrain.

How to contact your production unit

Sundsvall, Sweden



PU SUN
Permobil AB
Klökanvägen 16
863 41 Sundsvall
Sweden



+46 60 59 59 00



+46 60 57 52 50



info@permobil.com



www.permobil.com

Nashville, USA



PU NAS
Permobil Inc.
300 Duke Drive
Lebanon, TN 37090
USA



+1 800 736 0925



+1 800 231 3256



support@permobil.com



www.permobil.com

How to contact your local office

United States



Permobil Inc.
300 Duke Drive
Lebanon, TN 37090
USA



+1 800 736 0925



+1 800 231 3256



support@permobil.com



www.permobil.com



PU NAS

Dealer's address and telephone number

permobil

336699 eng-CAN



www.permobil.com